

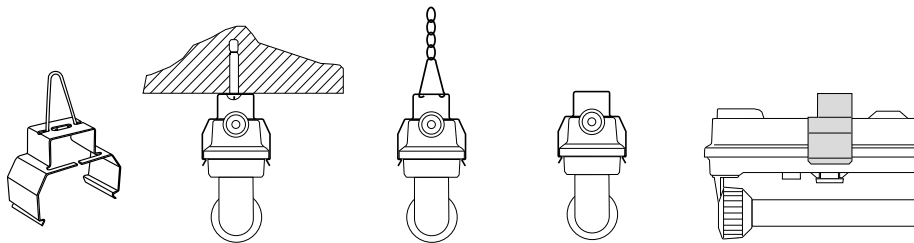

Taxon

IP65 weatherproof fixture for PlusLED T8 LED tubes

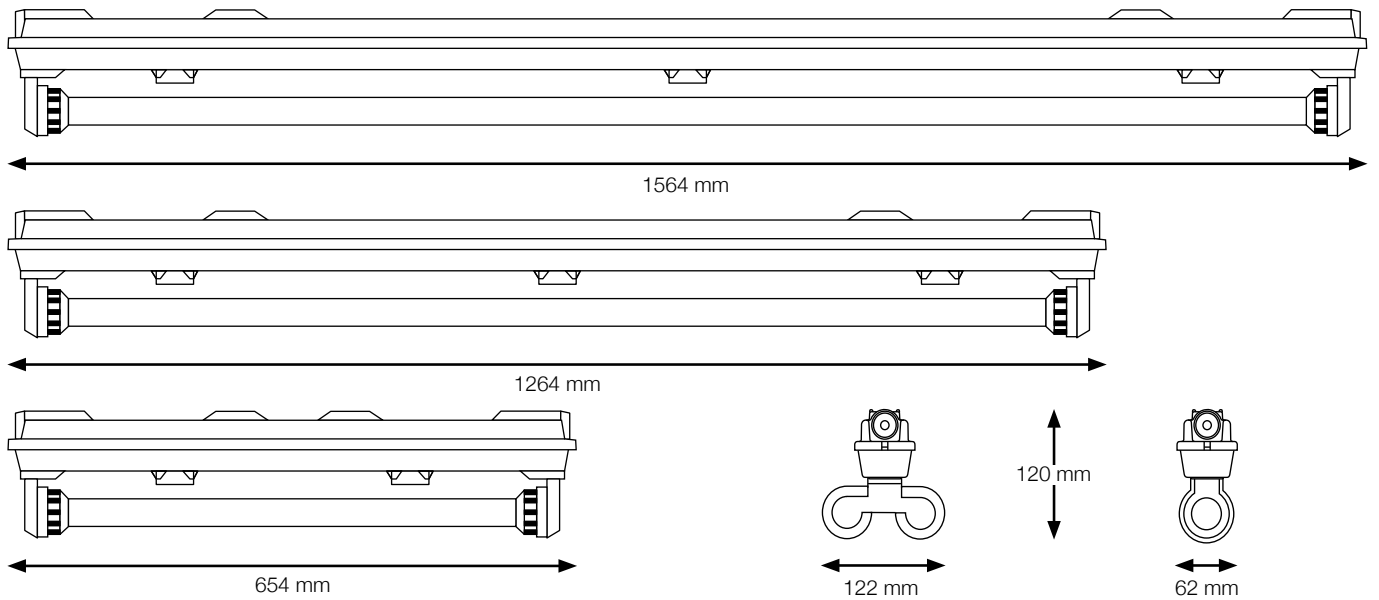

Mounting Kit

Applications

Taxon Fixtures are designed for the use with i-save PlusLED t8 tubes and are, due to their special construction (IP65 and protective tube) perfect for extreme surroundings.

There is no internal ballast needed, therefore maintenance costs are reduced drastically. This and the energy-saving instant on/off operation allow an improvement of the ROI.

Taxon fixtures are for in- and outdoor use.

Meets the requirements for usage in the food industry (IFS6, BRC 6, HACCP).

Features & Benefits

- 3 year warranty
- minor electricity consumption
- on / off operation
- usable worldwide 90-240 V, 50/60 Hz
- fast assemblage with mounting clamp (clip-in)
- adjustment of the fixture through flexible mounting area
- device for hanging installation (chain not included)
- high-quality stainless steel closures
- 2nd cable entry at the front-end (only in the double light fixture)
- surface-mounted and hanging installation possible
- compliant to IFS6, IFS Logistic 2.0, BRC 6, HACCP



Construction

Housing:	glass fibre reinforced polyester (RAL 7035), inflammable
sealing gasket:	EPDM
ceiling fixture:	stainless steel clamp
lamp:	i-SAVE PlusLED 600 mm, 1200 mm, 1500 mm
socket:	G13
protection class:	II
mechanical rating:	IP65

Weight

Taxon One 600 mm:	1,1 kg
Taxon One 1200 mm:	1,7 kg
Taxon One 1500 mm:	2,1 kg
Taxon Two 600 mm:	1,3 kg
Taxon Two 1200 mm:	2,4 kg
Taxon Two 1500 mm:	3,2 kg

Packaging Dimensions

Taxon One 600 mm	700 x 180 x 80 mm
Taxon One 1200 mm	1300 x 180 x 80 mm
Taxon One 1500 mm	1600 x 180 x 80 mm
Taxon Two 600 mm	700 x 190 x 115 mm
Taxon Two 1200 mm	1300 x 190 x 115 mm
Taxon Two 1500 mm	1600 x 190 x 115 mm

Installation

- hanging
- direct on ceiling
- mounting rail

Certifications

- CE
- RoHS
- ENEC

Technical sheet for i-save T8 LED tubes

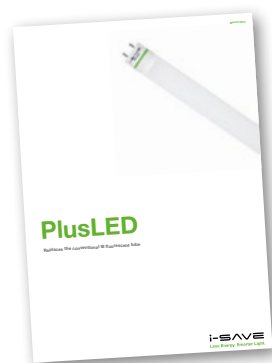

In our "Taxon" i-save PlusLED T8 tubes are used. please see the special technical sheet for further information. the sheet is available on our website: www.i-save-energy.com

Ordering codes

Ordering number	Name of product	Length
TX06-1	Taxon One	600 mm
TX12-1	Taxon One	1200 mm
TX15-1	Taxon One	1500 mm
TX06-2	Taxon Two	600 mm
TX12-2	Taxon Two	1200 mm
TX15-2	Taxon Two	1500 mm

i-SAVE
Less Energy. Smarter Light.

i-save energy GmbH

Spandauer Damm 86

D-14059 Berlin

Tel.: + 49 (0)30 797 08 00 00

Fax.: + 49 (0)30 797 08 00 09

Web: www.i-save-energy.com